



SAFETY CHECK LIST

**Concrete pumps
on the construction site**

Concrete pumps on the construction site

CHECK 1 **ACCESS ROAD**

- ▶ Safety distances

CHECK 2 **GROUND CONDITIONS**

- ▶ Load bearing capacity of the subsoil

CHECK 3 **STABILITY**

- ▶ Footprint
- ▶ Distances to excavation pits/shoring systems

CHECK 4 **SAFEGUARDS**

- ▶ Road traffic
- ▶ Overhead lines
- ▶ End hose

CHECK 5 **FALL PROTECTION**

- ▶ Lateral protection as safeguard
- ▶ Fall protection at the workplace

CHECK 6 **SAFETY**

- ▶ Workplace
- ▶ Weather conditions
- ▶ Decision making authority
- ▶ Responsibility

CHECK 1

▶ ACCESS ROAD ◀

Proper, load-bearing, unobstructed and sufficiently wide access road.

TO BE
PROVIDED
BY THE
CUSTOMER

Safety distance for passing

Access roads must be suitable for a machine weight of up to 63 tons and a machine height of approximately 4.00 m. Lines crossing the the access route – in/on/ under the road surface – must be adequately protected.

Clearance height
 ≥ 4.00 m

Safety distance from
unshored excavation
pits ≥ 2.00 m

Safety distance from
shored excavation pits
 ≥ 1.00 m

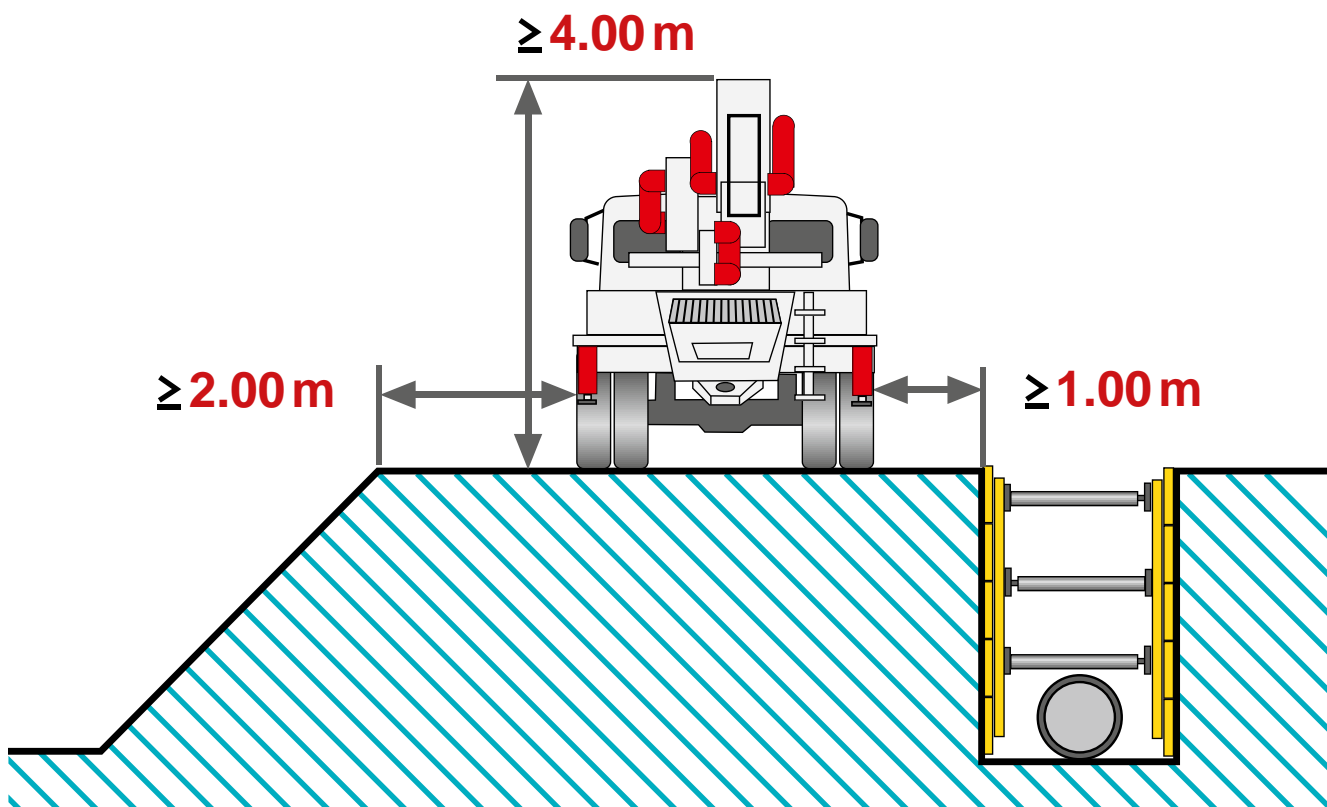

CHECK 2

▶ GROUND CONDITIONS ◀

**TO BE
PROVIDED
BY THE
CUSTOMER**

**Before setting up the pump:
Proof of subsoil load bearing capacity at the installation location.**

**Construction
management | the
construction company
is responsible for the
standard ground values!**

Protection against ground collapse

Checking the load bearing capacity of the subsoil is very important! When setting up and supporting vehicles on unpaved ground, there is a risk of ground collapse due to settling, ground break and perforation.

Ground collapse depends on the type of soil and degree of compaction. The vehicle may tilt and can tip over under unfavourable conditions.

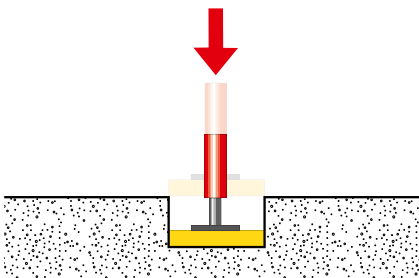

Settling

In case of settling, the ground sinks due to compaction of the soil particles but usually consolidates after a few centimetres.

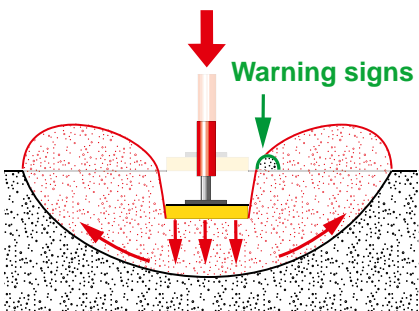

Ground break

In a ground break, the soil is displaced sideways and upward due to overloading by shear forces, and the support sinks in. This occurs in particular with soft and mushy, compact soil. Proximity to an embankment favours a ground break.

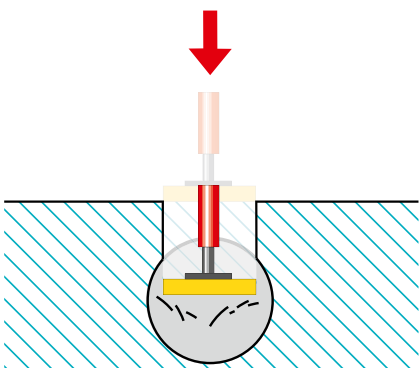

Perforation

In case of perforation, the ground collapse or ground break occurs abruptly without any warning signs.

Required supporting surface depending on the soil type using 4 pump sizes as examples

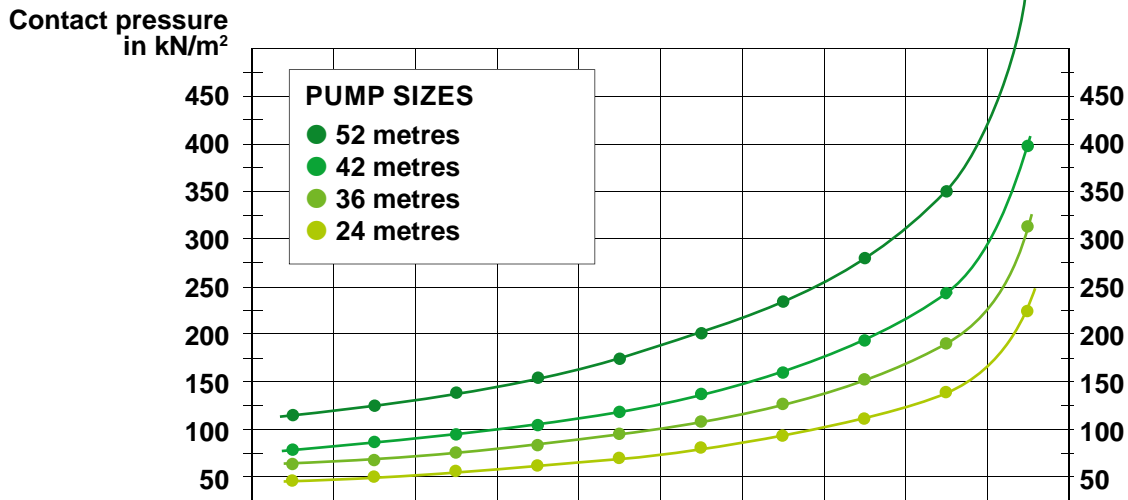

		SUPPORTING SURFACE IN M ²											
		3	2,75	2,5	2,25	2	1,75	1,5	1,25	1	0,6		
Soil type Subsoil	PUMP SIZE											Permissible ground pressure in kN/m ²	
Solid rock (limestone, granite)	52											2000 – 4000	
	42												
	36												
	24												
Paved road	52											300 – 1000	
	42												
	36												
	24												
Backfilled, compacted ground (gravel bed)	52											250	
	42												
	36												
	24												
Backfilled, not artificially compacted ground	52											0 – 100	
	42												
	36												
	24												
Non-compact soil without sufficient support	52											150 – 300	
	42												
	36												
	24												
Non-compact soil, fine to medium sand, coarse sand to gravel	52											200 – 500	
	42												
	36												
	24												
Moist loam (soft)	52											50 – 100	
	42												
	36												
	24												
Dry loam (hard)	52											100 – 200	
	42												
	36												
	24												
Clay (semi-solid)	52											150 – 250	
	42												
	36												
	24												
Gypsum, sandstone (hard)	52											300	
	42												
	36												
	24												

IMPORTANT: Non-binding guiding values.
See the respective operating manual for the concrete pump for actual values.

CHECK 3

▶ STABILITY ◀

**TO BE
PROVIDED
BY THE
CUSTOMER**

Proof of adequate compaction of fill and structural analysis for any basement walls required.

Safety distances to excavation pits | shoring system

Aside from the ground conditions, the distances to excavation pits and embankments/shoring systems as well as previously constructed basement walls/sewer installations must be observed! If complying with the distances is not possible, a state-of-the-art calculation of the embankment stability is required.

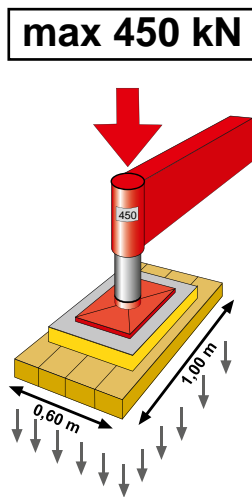

**Ground pressure at
0.6m² can be
up to 750 kN/m².**

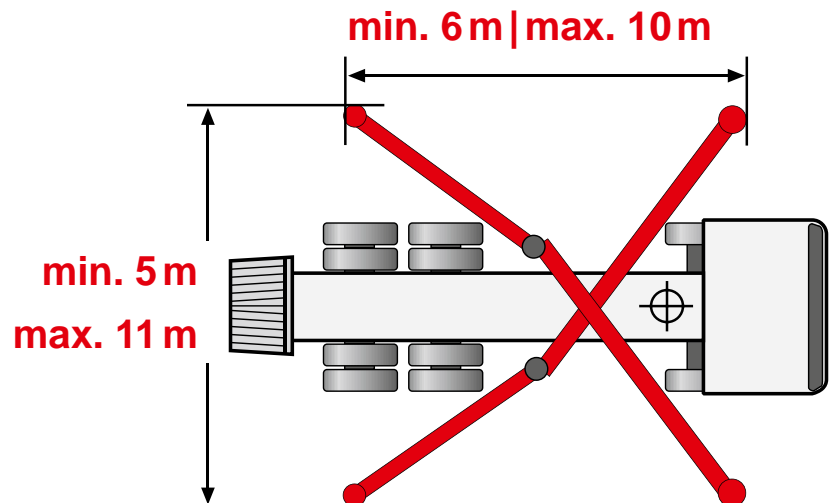

Safety distance for

natural, cohesive soil (up to 40 tons at least 2m)	A ~ 1 x T
backfilled, non-cohesive soil	A ~ 2 x T

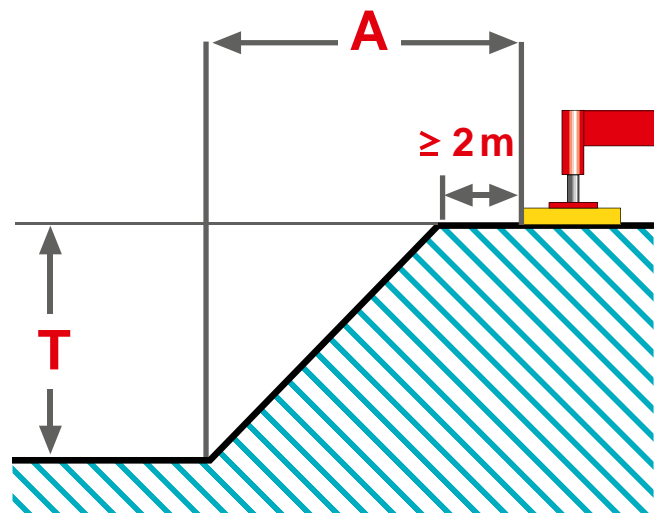

CHECK 4

▶ SAFEGUARDS ◀

Clear splash zone around the concrete pump.
Permit for road blocks and power cut-off as required.

TO BE
PROVIDED
BY THE
CUSTOMER

Note danger area (L)!

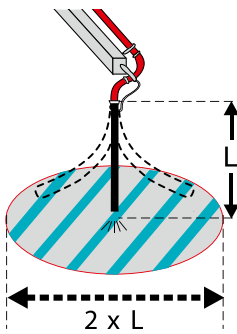

PROHIBITED
Presence of persons
in the danger area
when pumping starts!

PROHIBITED
Fixed end pieces
or reducers
on the end hose!

On the end hose

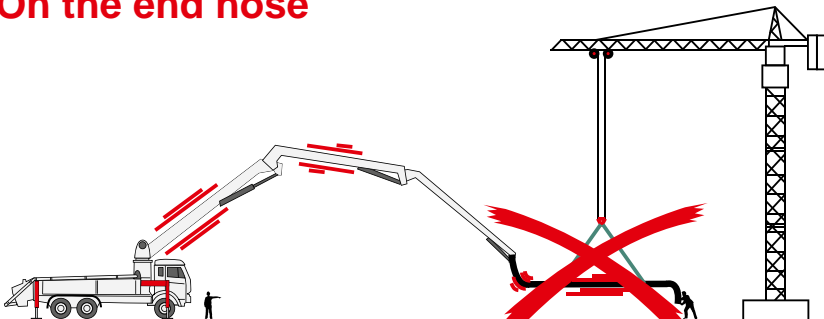

PROHIBITED
Use of traverses!

In road traffic

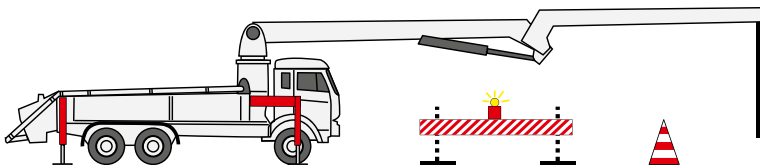

Approvals
for road blocks

To overhead lines

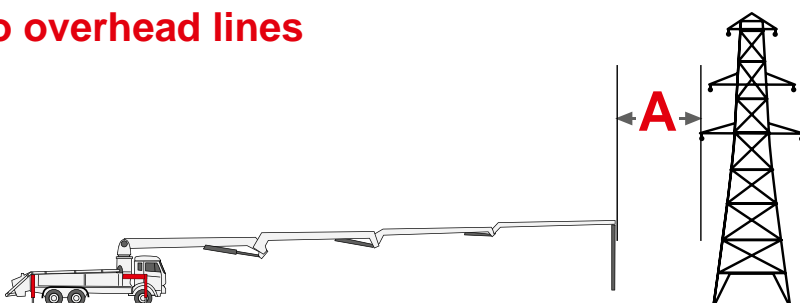

Safety distance
to live lines
 $A \geq 5 \text{ m}$

CHECK 5

▶ FALL PROTECTION ◀

**TO BE
PROVIDED
BY THE
CUSTOMER**

Fall protection on the structure and traffic routes in the form of scaffolds, railings, lateral protection or fixed guards.

Lateral protection as safeguard

Missing, incompletely installed or incorrectly dimensioned fall protection, and lack of safety measures during installation, can lead to accidents due to falling.

Lateral protection dimensions

The railing and intermediate rail must be secured against coming loose unintentionally, and the toe board against tilting. Toe boards have to project over the covering by at least 15 cm, minimum thickness 3 cm.

**Secure boards
against coming loose
and tilting.**

**Up to 2 m post spacing,
all boards min.
150 x 30 mm
(height x thickness)**

Up to 3 m post spacing

Wooden boards $\geq 200 \times 40$ mm
Steel pipes $\geq \varnothing 48.3 \times 3.2$ mm
Aluminium pipes $\geq \varnothing 48.3 \times 4$ mm

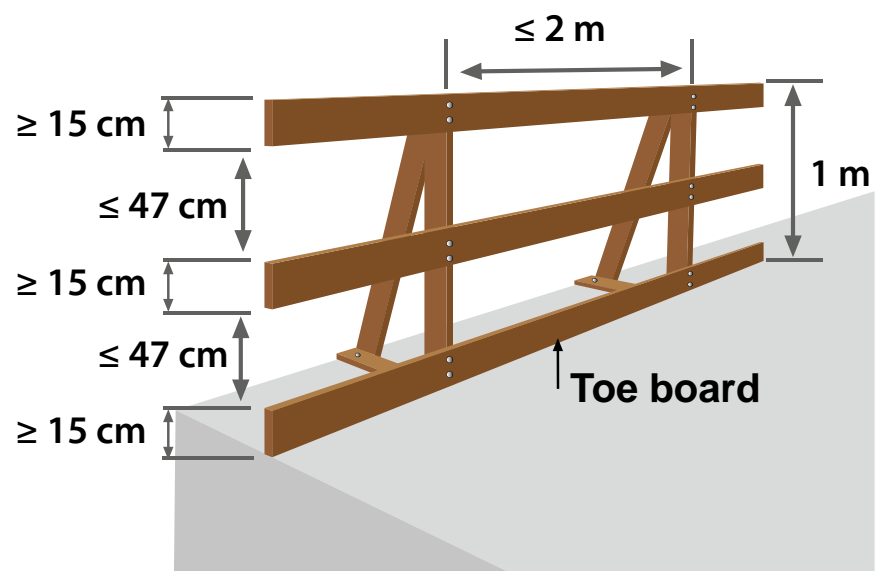

Near or above liquids

Workplaces and traffic routes near or above substances one can sink into (e.g. water) must be secured regardless of the fall height.

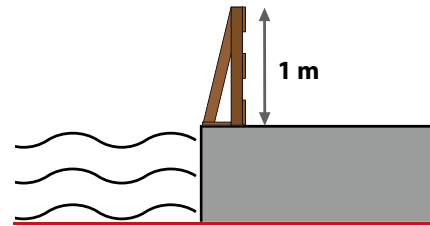

Fall height more than 2 m

If the fall height is more than 2 m, all workplaces or traffic routes must be secured.

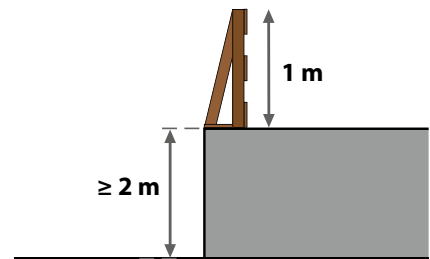

Stairs with a fall height of 1 m and up

Exposed flights of stairs and landings must be secured with fall protection at a height of 1 m and up.

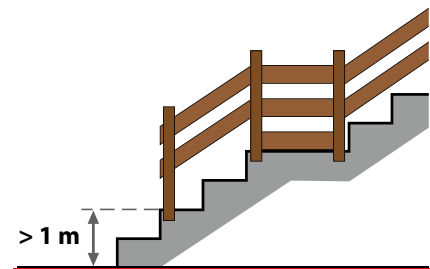

On wall openings

Openings in walls with a fall height of 1 m and up must be secured.

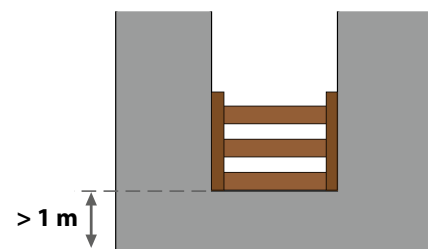

On openings and pits

For openings/pits in floors, ceilings and roof areas,

- ▶ lateral protection is not required if they are closed by covers that can be walked on and that cannot be shifted.
- ▶ lateral protection is required if they are larger than 9 m^2 with an edge length of more than 3 m.

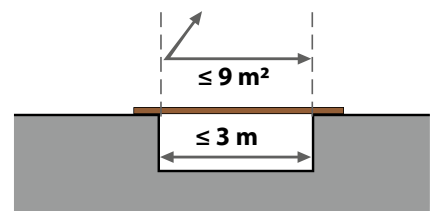

CHECK 5

▶ FALL PROTECTION ◀

Fall protection at the workplace

The hose guide and pump operator must be protected against falling.

Workplaces at a height of 2 m and up generally require fall protection.

PROHIBITED
Using the top of any kind of formwork as a place to stand!

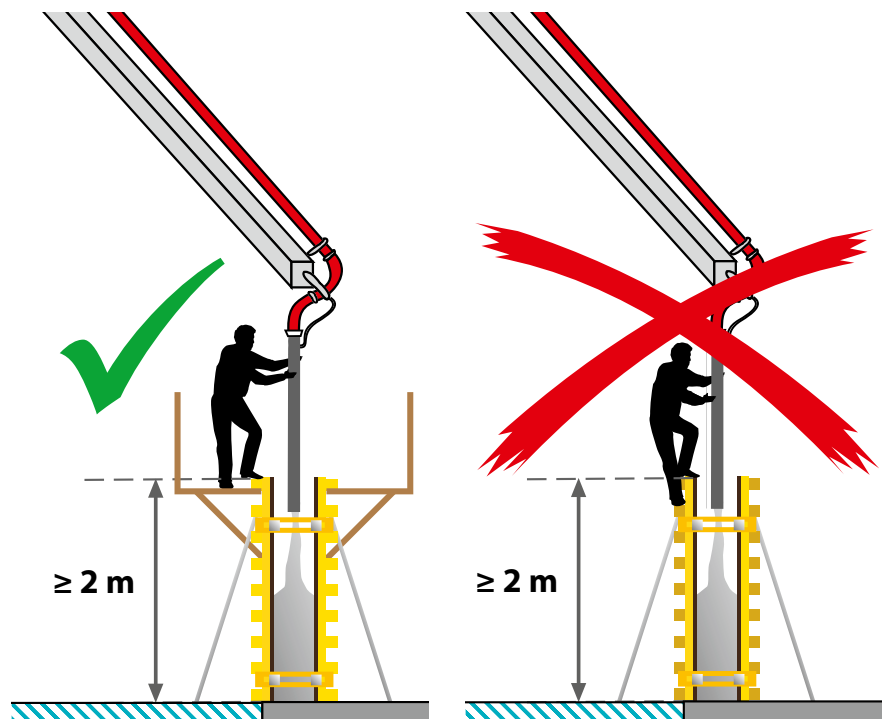

Other fall protection measures

- ▶ Lateral protection/blocking off can only be omitted if safety scaffolds, roof safety scaffolds, safety nets or protective walls have been installed.
- ▶ Only when safety catch devices are inappropriate may personal protective equipment against falling be used.

Concreting without fall protection

In case of **ground floor ceilings** with a **fall height below 3 m**, fall protection can be omitted if the work is carried out by technically qualified and physically suitable employees. The fall edge must be clearly discernible.

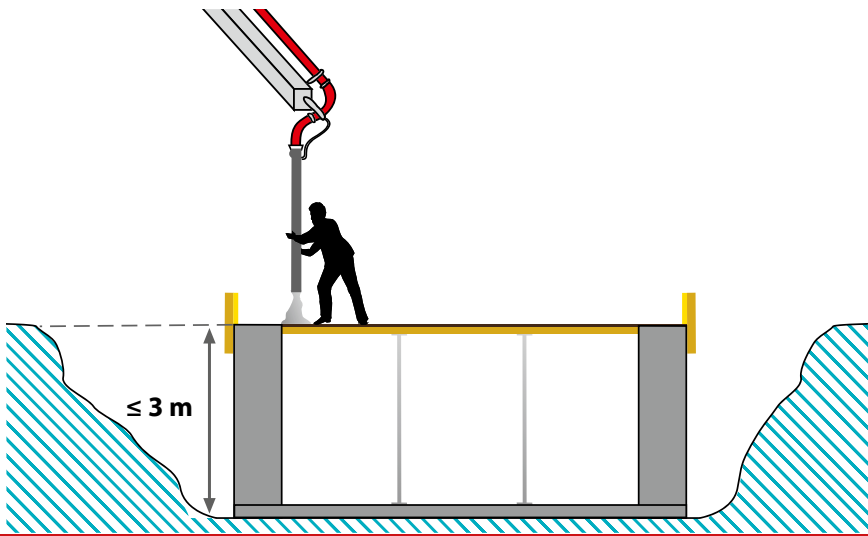

Fall protection can be omitted in case of a ground floor ceiling and a ≥ 3 m fall height.

The fall edge must be clearly discernible.

Concreting on structures that are not properly secured – compromise solution –

In case of **upper floor ceilings** with a **fall height below 3 m** and a **base area above 50 m²** without fall protection, a safety distance of 2 metres to the fall edge must be maintained. Within this safety distance, concreting has to be carried out with no end hose guide.

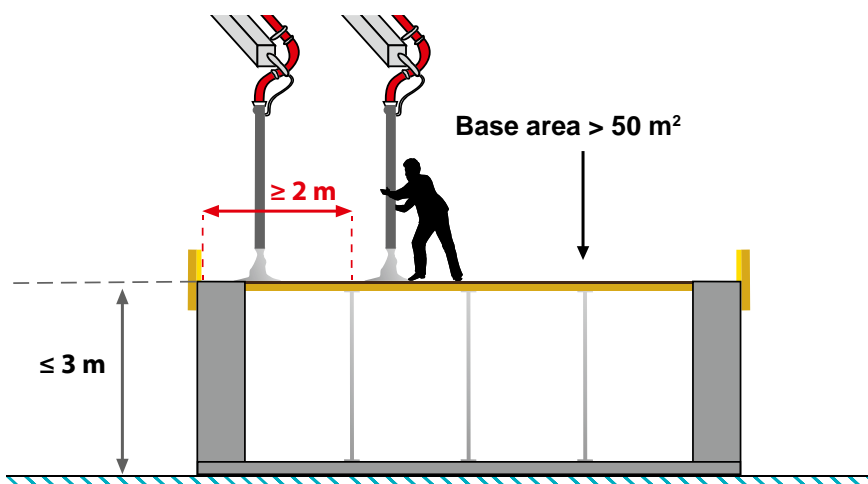

COMPROMISE SOLUTION
In case of an upper floor ceiling with a fall height ≤ 3 m and a base area > 50 m², concreting within the safety distance of 2 metres to the fall edge has to be carried out with no end hose guide.

An end hose guide is only used for concreting outside the safety distance of 2 m from the fall edge.

CHECK 6

▶ SAFETY ◀

**TO BE
PROVIDED
BY THE
CUSTOMER**

**Sufficient helpers for setup, removal and cleaning.
Trained guides for the truck mixers.
Instruction of the end hose guide.**

Workplace

- ▶ All employees must wear personal protective equipment (PPE).
- ▶ Danger areas must be observed: around the mast, especially the end hose, and around the pump and truck mixer.

Weather conditions

There is a risk of machinery breakage

- ▶ if temperatures are too low.
- ▶ if the wind is too high (e.g. when green leaves are torn off the trees).
- ▶ Move the boom to the travel or idle position in case of a wind storm or thunderstorm.

Decision making authority

- ▶ The pump operator makes the final decision whether using their equipment is possible.
- ▶ The instructions of the operator must be followed!

Responsibility

- ▶ Are all required papers and documents from the builder/construction management on hand?
 - ▶ Road blocks
 - ▶ Load bearing capacity of the subsoil
 - ▶ Structural analysis

Wear protective equipment!

Note danger areas!

Fall protection!

Pump operation prohibited

- ▶ below -15°C
- ▶ at wind speed $8 < 40\text{-metre class}$
- ▶ at wind speed $7 \geq 40\text{-metre class}$

**The pump operator decides
whether or not
the equipment can be used!**

Provided by: